

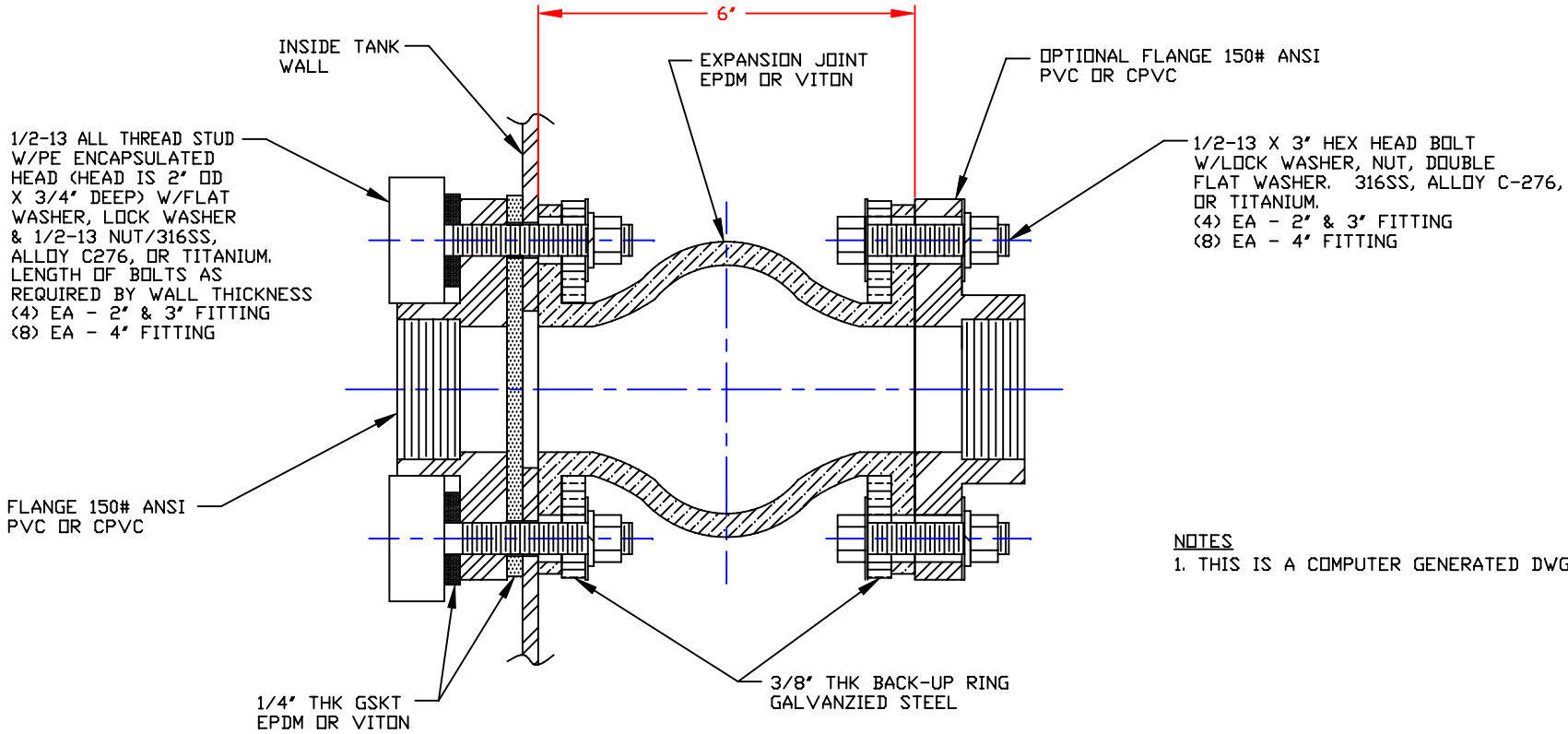

NON-CONTROLLED COPY  
 INFORMATION SUBJECT TO CHANGE WITHOUT NOTICE  
 VERIFY REV LEVEL OF PAPER COPY WITH REV LEVEL ON PPC WEB SITE



**NOTES**  
 1. THIS IS A COMPUTER GENERATED DWG. DO NOT REVISE BY HAND.

CONFIDENTIAL PROPERTY OF  
 POLY PROCESSING COMPANY  
 NOT FOR REPRINT OR USE  
 WITHOUT PERMISSION

DWG TITLE 2", 3", & 4" FLEXI-JOINT FITTING ASSEMBLY			
SCALE: 6"=1'-0"	 <b>POLYPROCESSING</b> COMPANY	Central Region P.O. Box 4150 (71211) 2201 Old Stovington Rd. Harveys, LA 70059 CUB 343-7565 FAX 504-343-8790	DR: MB WILKERSON CK: J. SUTTON
DATE: 6/22/05		SHEET 1 OF 1	COMPUTER FILE FLXJNTFTG