

NON-CONTROLLED COPY
 INFORMATION SUBJECT TO CHANGE WITHOUT NOTICE
 VERIFY REV LEVEL OF PAPER COPY WITH REV LEVEL ON PPC WEB SITE

REV 'A' ADDED BOX ON TANK DOME BY:JB 9/26/01 CK:MBW
 REV 'B' ADDED DIMENSION BY:JB 10/8/02 CK:MBW
 REV 'C' ADDED FITTING NOTE BY:JB 3/19/03 CK:MBW
 REV 'D' ADDED BOXES @ 90° & 180° BY:MBW 7/19/04 CK:JB
 REV 'E' CORRECTED ELEV VIEW BY:JB 1/6/09 CK:SN

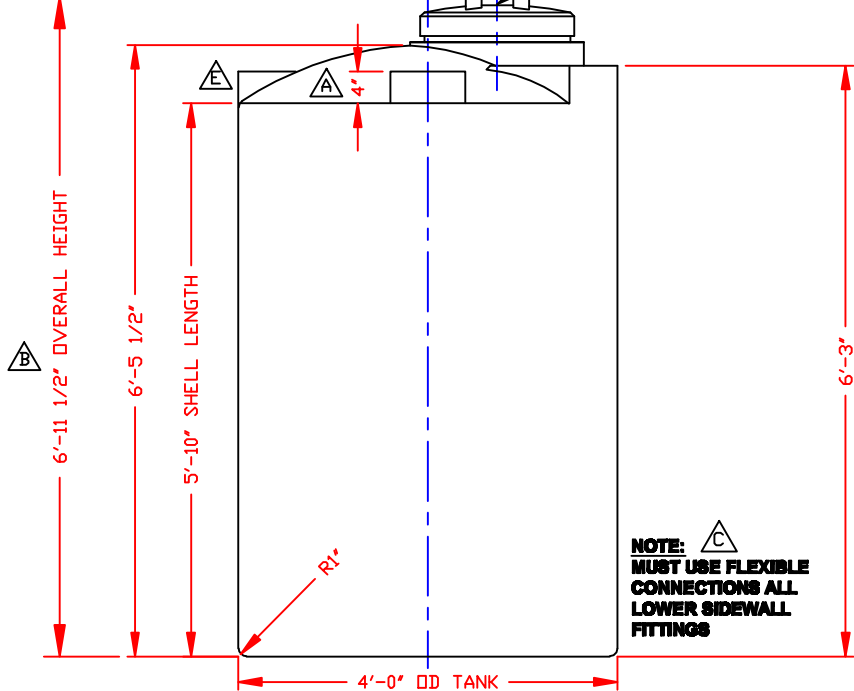
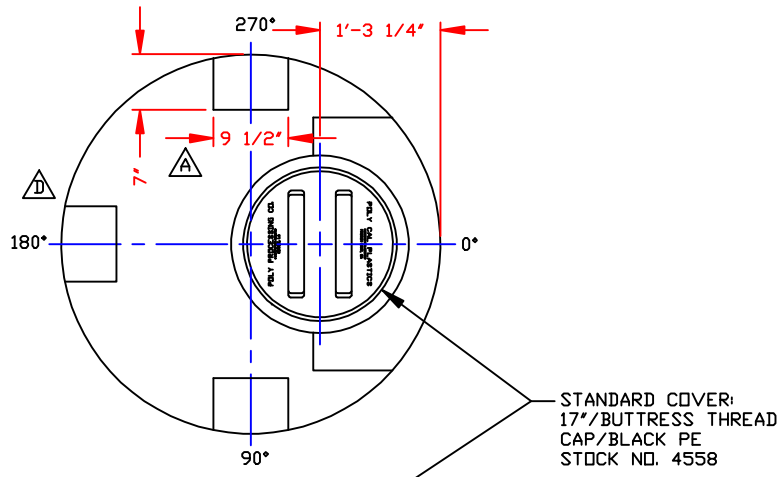

NOZZLE SCHEDULE & ACCESSORIES						
SERVICE	MK	STOCK NO.	SIZE	FITTING	DEG	ELEV

NOTES
 1. THIS IS A COMPUTER GENERATED DWG. DO NOT REVISE BY HAND.
 2. DIMENSIONS WILL VARY ±3% DUE TO VARIATIONS IN MULTIPLE MOLDS & CONDITIONS PREVALENT DURING MANUFACTURE & USAGE.
 3. MOLDED IN GALLONAGE MARKERS @ 0° IN 50 GALLON INCREMENTS STARTING @ 50 GAL UP TO 400 GAL. AVOID WHEN PLACING FITTINGS.

CALCULATED CAPACITIES/ VOLUME IN U.S. GALLONS		
DESIGN CAP	DOME VOL	TOTAL VOL
540	25	565

CONFIDENTIAL PROPERTY OF
 POLY PROCESSING COMPANY
 NOT FOR REPRINT OR USE
 WITHOUT PERMISSION

DWG TITLE		540 GALLON UPRIGHT TANK		
SCALE:	3/4"=1'-0"	<p>Western Region P.O. Box 88 5255 South Ash Street French Camp, CA 95821 (925) 948-7500 FAX (925) 948-9455</p>	DR:	MB WILKERSON
DATE:	2/26/00		CK:	D. RECTOR
SHEET	COMPUTER FILE	REV		
1 OF 1	11000540	E		