

NON-CONTROLLED COPY  
 INFORMATION SUBJECT TO CHANGE WITHOUT NOTICE  
 VERIFY REV LEVEL OF PAPER COPY WITH REV LEVEL ON PPC WEB SITE

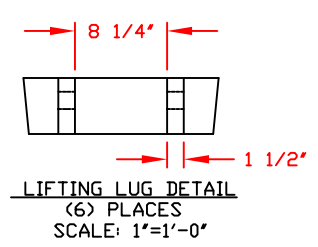
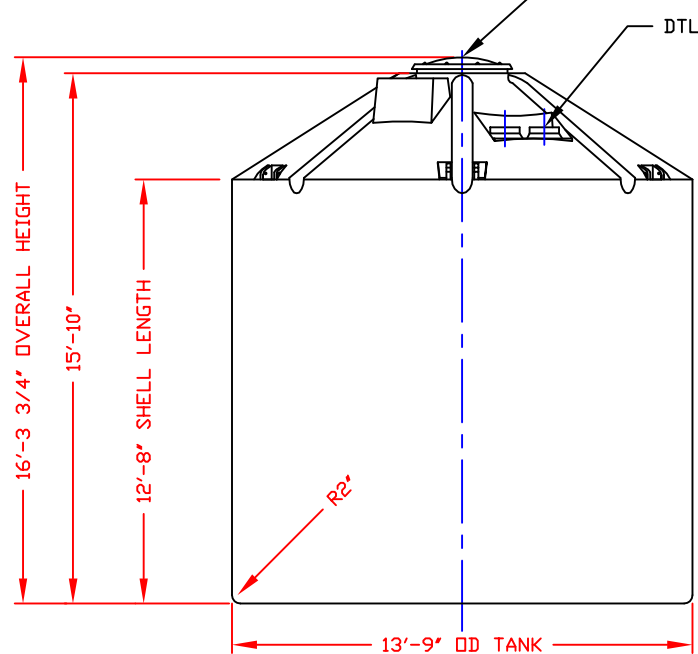
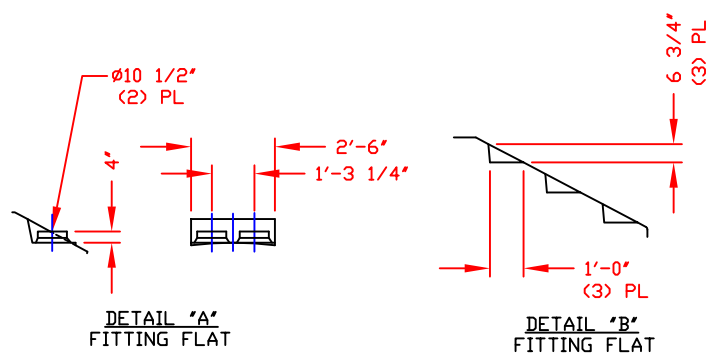
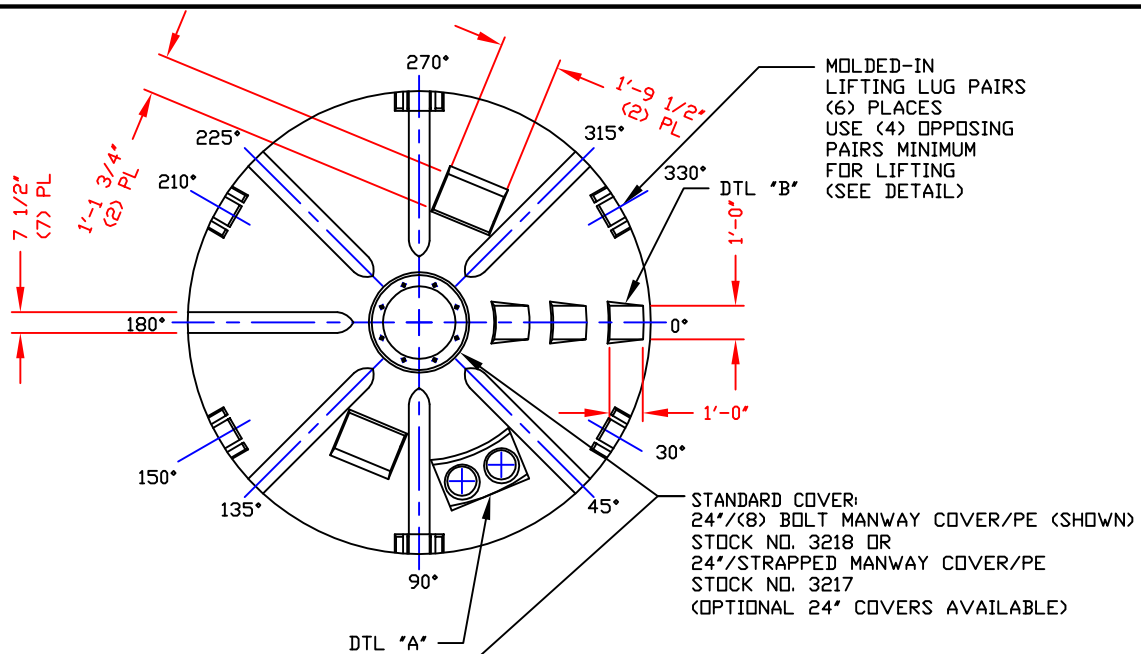

**NOTES**  
 1. THIS A COMPUTER GENERATED DWG. DO NOT REVISE BY HAND.  
 2. DIMENSIONS WILL VARY  $\pm 3\%$  DUE VARIATIONS IN MULTIPLE MOLDS & CONDITIONS PREVALENT DURING MANUFACTURE & USAGE.  
 3. NO MOLDED IN GALLONAGE MARKERS THIS TANK.

**NOTE:**  
 MUST USE FLEXIBLE CONNECTIONS ALL LOWER SIDEWALL FITTINGS

CALCULATED CAPACITIES/ VOLUME IN U.S. GALLONS		
DESIGN CAP	DOME VOL	TOTAL VOL
13652	1330	14982

CONFIDENTIAL PROPERTY OF  
 POLY PROCESSING COMPANY  
 NOT FOR REPRINT OR USE  
 WITHOUT PERMISSION

DWG TITLE			13650 GALLON UPRIGHT TANK		
SCALE:	1/4"=1'-0"	 Western Region P.O. Box 80 8035 South Ash Street French Camp, CA 95531 (530) 982-4964 FAX (530) 982-6455	DR:	B. DUMAS	
DATE:	12/6/07		CK:	W. MANUEL	
		SHEET	COMPUTER FILE	REV	
		1 OF 1	11013650	-	