

NON-CONTROLLED COPY
 INFORMATION SUBJECT TO CHANGE WITHOUT NOTICE
 COPY WILL NOT BE UPDATED

COPY ISSUED BY _____
 COPY ISSUED ON _____

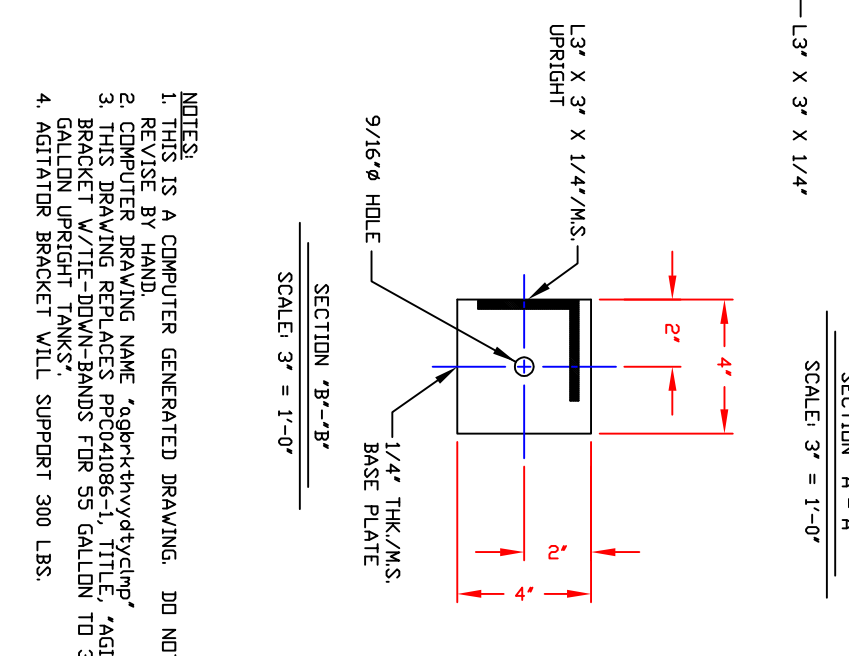
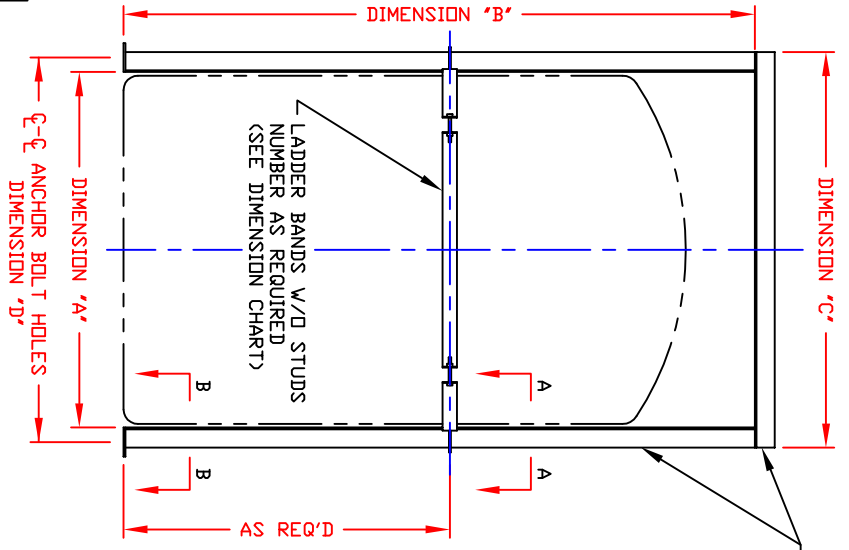
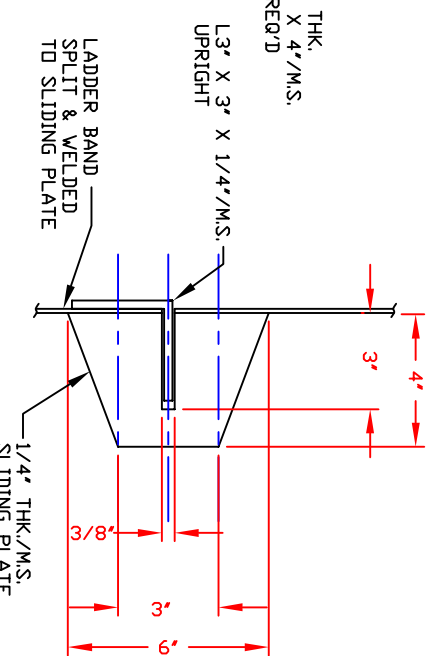
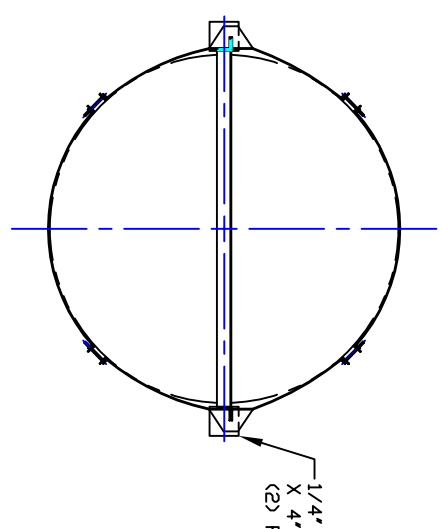

NOTES:
 1. THIS IS A COMPUTER GENERATED DRAWING. DO NOT REVISE BY HAND.
 2. COMPUTER DRAWING NAME 'agor-k-thy-y-d-ty-clmp', 'AGITATOR', 'BRACKET W/TIE-DOWN-BANDS FOR 55 GALLON TD 3,000 GALLON UPRIGHT TANKS', 'AGITATOR UPRIGHT TANKS', 'GALLON UPRIGHT TANKS', 'AGITATOR BRACKET WILL SUPPORT 300 LBS.'

DIMENSION CHART

TANK	A	B	C	D	BANDS REQUIRED	PART NUMBER
55 SAFE TANK	37'	35'	43'	41'	(3) 35' BANDS	5195
60	24'	48'	30'	28'	(2) 35' BANDS	3667
115	31'	51'	37'	35'	(2) 47' BANDS	
105 SAFE TANK	37'	50'	43'	41'	(3) 35' BANDS	5196
155	32'	62'	38'	36'	(2) 48' BANDS	3669
160 SAFE TANK	37'	66'	43'	41'	(1) 48' BAND	5197
175	39'	54'	45'	43'	(1) 48' BAND	5198
205	32'	79'	38'	36'	(2) 48' BANDS	3670
280	35'	89'	41'	39'	(3) 35' BANDS	5199
295	47'	59'	53'	51'	(4) 35' BANDS	3671
450	47'	80'	53'	51'	(4) 35' BANDS	3672
475	49'	81'	55'	53'	(3) 48' BANDS	5200
495	65'	54'	71'	69'	(4) 48' BANDS	3673
505 OPEN TOP	49'	73'	55'	53'	(3) 48' BANDS	5190
540 SAFE TANK	78'	54'	84'	82'	(2) 48' BANDS	3674
545 IMFD	49'	89'	55'	53'	(3) 48' BANDS	3675
555 OPEN TOP	78'	40'	84'	82'	(3) 48' BANDS	3692
755	65'	75'	71'	69'	(4) 48' BANDS	3678
805	49'	125'	55'	53'	(3) 48' BANDS	3676
830 IMFD	49'	129'	55'	53'	(3) 48' BANDS	3677
905	65'	88'	71'	69'	(4) 48' BANDS	3679
905 IMFD	65'	87'	71'	69'	(4) 48' BANDS	3680
1000	87'	62'	93'	91'	(4) 65' BANDS	3681
1050	62'	108'	68'	66'	(1) 48' BAND	5201
					(1) 65' BAND	
					(1) 72' BAND	
1100 OPEN TOP	62'	96'	68'	66'	(4) 48' BANDS	5191
1150	65'	104'	71'	69'	(4) 48' BANDS	3682
1300	86'	76'	92'	90'	(4) 65' BANDS	3683
1400	65'	126'	71'	69'	(4) 48' BANDS	3684
1400 IMFD	65'	125'	71'	69'	(4) 48' BANDS	3685
1550 SAFE TANK	97'	91'	103'	101'	(4) 72' BANDS	3693
1700	97'	80'	103'	101'	(4) 72' BANDS	3686
1950 OPEN TOP	97'	70'	103'	101'	(4) 72' BANDS	3693
2000 IMFD	86'	108'	92'	90'	(4) 65' BANDS	3687
2250	97'	100'	103'	101'	(4) 72' BANDS	3688
2350 IMFD	86'	129'	92'	90'	(4) 65' BANDS	3689
2650	97'	112'	103'	101'	(4) 72' BANDS	3690
3000 IMFD	86'	152'	92'	90'	(4) 65' BANDS	3691

NOTE
 FOR TANKS NOT LISTED:
 DIMENSION 'A' = TANK DD + 1'
 DIMENSION 'B' = OVERALL HEIGHT + 6'
 DIMENSION 'C' = DIMENSION 'A' + 4'
 DIMENSION 'D' = DIMENSION 'A' + 4'

DWG. TITLE: CLAMP ON AGITATOR BRACKET'S-HEAVY DUTY-VERT TANKS
 (55 GALLON TD 3050 GALLON UPRIGHT TANKS)

SCALE: NONE

DATE: 11/03/11

POLY PROCESSING CO.

DWG. NO. 1 OF 1

DR. B THURMON

REV.