

- NOTES:**
1. WT OF AGITATOR NOT TO EXCEED 400 LBS.
  2. THIS UNIT TO BE ERRECTED @ FABRICATOR'S SITE TO CHECK FOR COMPLETENESS/DISASSEMBLE & BAG ALL NUTS, BOLTS, ETC.
  3. BRACE MUST NOT INTERFERE W/AGITATOR PLATE LOCATION PER CUSTOMER SPEC.
  4. AGITATOR BRIDGE CRUSSES @ OF TANK.

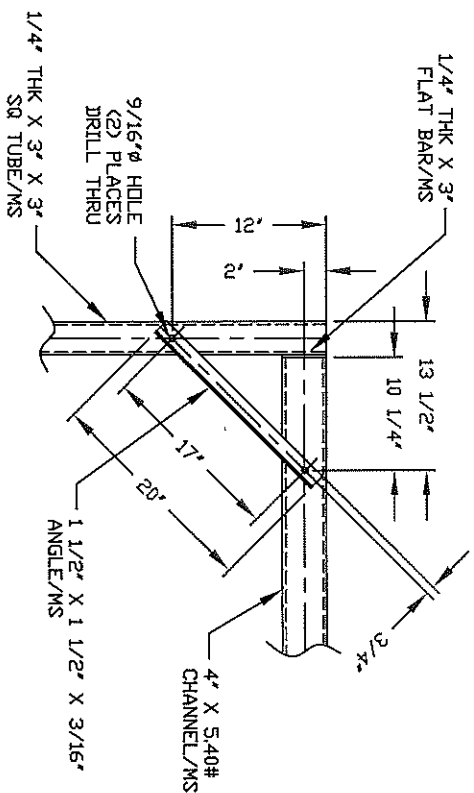

**DIMENSION CHART**

| TANK      | DIM 'A' | DIM 'B' |
|-----------|---------|---------|
| 540       | 50"     | 89"     |
| 805       | 50"     | 124"    |
| 905       | 66"     | 90"     |
| 1000      | 87"     | 64"     |
| 1150      | 66"     | 106"    |
| 1300      | 87"     | 69"     |
| 1400      | 66"     | 128"    |
| 1450      | 87"     | 82"     |
| 1700      | 98"     | 81"     |
| 2250      | 98"     | 98"     |
| 2650      | 98"     | 115"    |
| 540ST     | 76"     | 60"     |
| 1000ST    | 79"     | 89"     |
| 1550ST    | 98"     | 94"     |
| 3150ST    | 124"    | 104"    |
| 545 IMFD  | 50"     | 91"     |
| 850 IMFD  | 50"     | 130"    |
| 1400 IMFD | 66"     | 128"    |
| 2000 IMFD | 86"     | 108"    |
| 2550 IMFD | 86"     | 129"    |
| 3000 IMFD | 86"     | 150"    |

NOTE! USE SAME DIMENSIONS FOR OPEN TOP TANKS AS FOR CLUSED TOP TANKS

**DWG TITLE**  
**FREE STANDING AGITATOR BRACKET FOR**  
**540 TO 3150 GALLON TANKS**

|       |            |  |                                    |
|-------|------------|--|------------------------------------|
| SCALE | 1/2"=1'-0" | <p>Central Region<br/>                 PolyProcessing<br/>                 Company, Inc.<br/>                 2500 25th St<br/>                 P.O. Box 250<br/>                 P.O. Box 250<br/>                 P.O. Box 250<br/>                 P.O. Box 250<br/>                 P.O. Box 250</p> | DRN MB WILKERSON<br>CKI B. THURMON |
| DATE  | 4/20/05    |  |                                    |
| SHEET | 1 OF 2     | COMPUTER FILE  | AGBRKT400                          |
| REV   | -          |  |                                    |

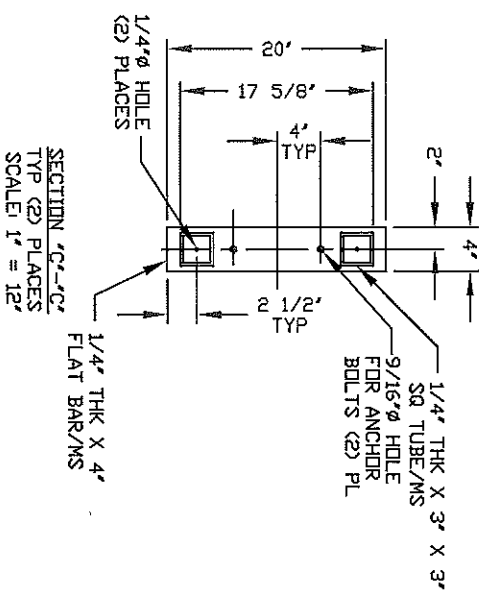
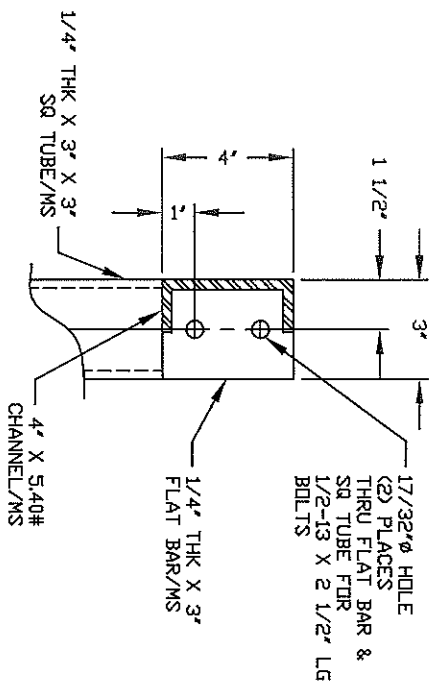
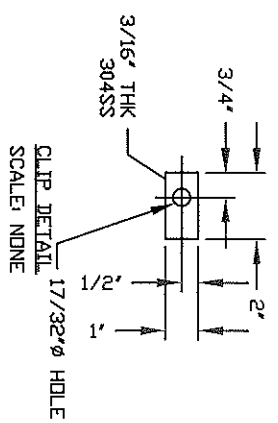
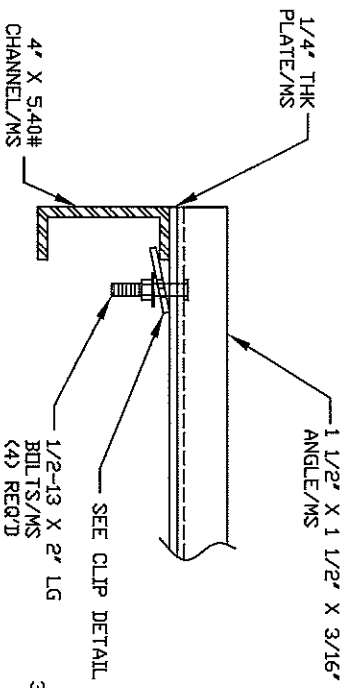
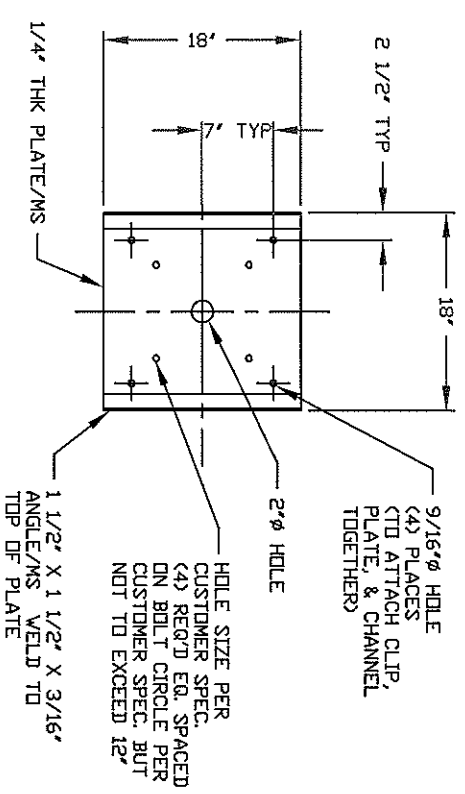

DWG TITLE  
**FREE STANDING AGITATOR BRACKET FOR 540 TO 3150 GALLON TANKS**

|        |              |        |   |                     |
|--------|--------------|--------|---|---------------------|
| SCALE: | 1/2" = 1'-0" |        | Central Region<br>1000 N. 10th Street<br>P.O. Box 200<br>Fort Collins, CO 80501<br>(970) 226-2000 | JWB<br>MB WILKERSON |
| DATE:  | 4/20/05      |        |   |                     |
| SHEET  |              | 2 OF 2 | AGBRKT400   | REV                 |