

NON-CONTROLLED COPY  
 INFORMATION SUBJECT TO CHANGE WITHOUT NOTICE  
 VERIFY REV LEVEL OF PAPER COPY WITH REV LEVEL ON PPC WEB SITE

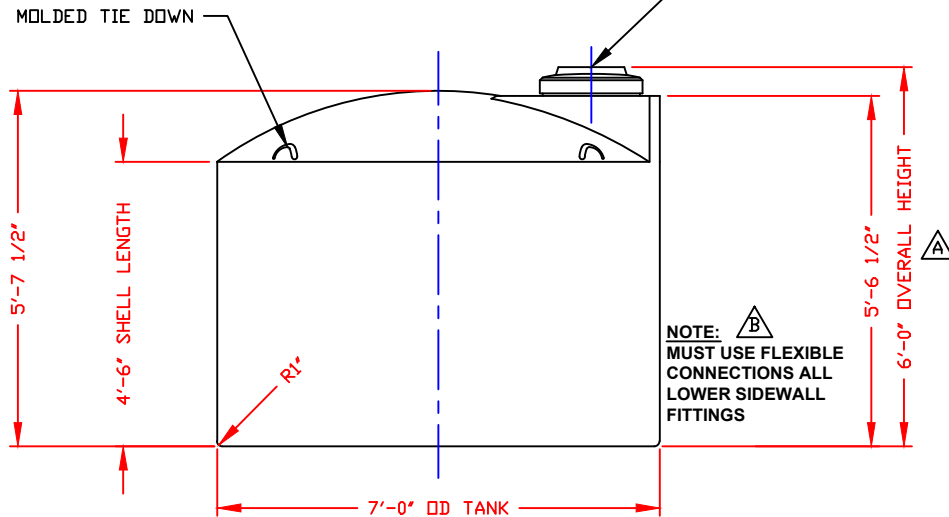
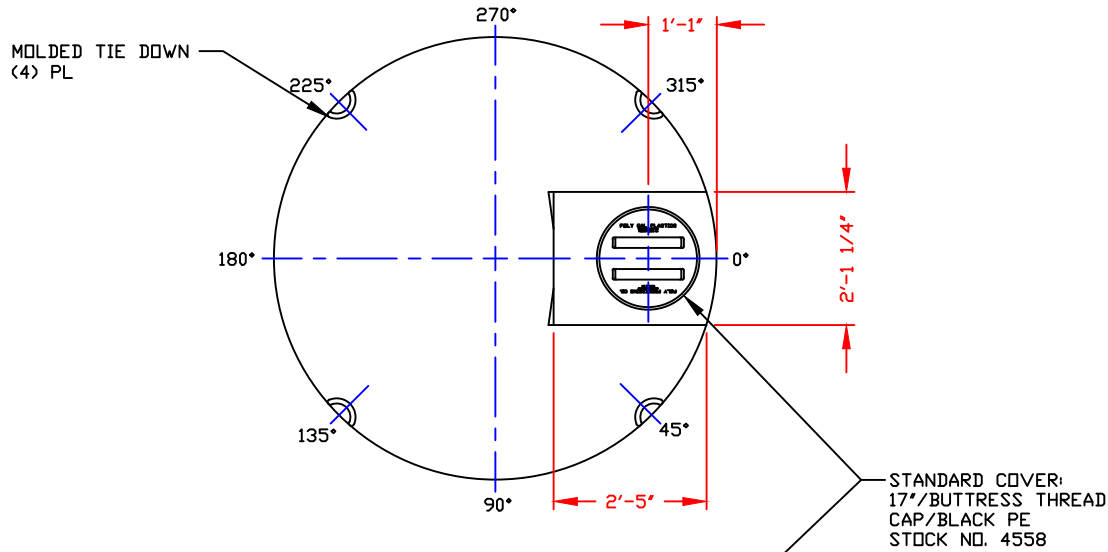

NOZZLE SCHEDULE & ACCESSORIES						
SERVICE	MK	STOCK NO.	SIZE	FITTING	DEG	ELEV

- NOTES**
1. THIS IS A COMPUTER GENERATED DWG. DO NOT REVISE BY HAND.
  2. DIMENSIONS WILL VARY ±3% DUE TO VARIATIONS IN MULTIPLE MOLDS & CONDITIONS PREVALENT DURING MANUFACTURE & USAGE.
  3. NO MOLDED IN GALLONAGE MARKERS THIS TANK.

CALCULATED CAPACITIES/ VOLUME IN U.S. GALLONS		
DESIGN CAP	DOME VOL	TOTAL VOL
1282	165	1447

CONFIDENTIAL PROPERTY OF  
 POLY PROCESSING COMPANY  
 NOT FOR REPRINT OR USE  
 WITHOUT PERMISSION

DWG TITLE			
1250 GALLON UPRIGHT TANK			
SCALE: 1/2"=1'-0"	<p>Western Region          P.O. Box 88          8025 South Ash Street          French Camp, CA 92521          (951) 962-0100          FAX (951) 962-0455</p>	DR: MB WILKERSON	
DATE: 2/28/00		CK: D. RECTOR	
SHEET		COMPUTER FILE	REV
1 OF 1		11001250	B

REV "B" ADDED FITTING NOTE BY:JB 3/19/03 CK:MBW  
 REV "A" ADDED DIMENSION BY:JB 10/15/02 CK:MBW