

NON-CONTROLLED COPY  
 INFORMATION SUBJECT TO CHANGE WITHOUT NOTICE  
 VERIFY REV LEVEL OF PAPER COPY WITH REV LEVEL ON PPC WEB SITE

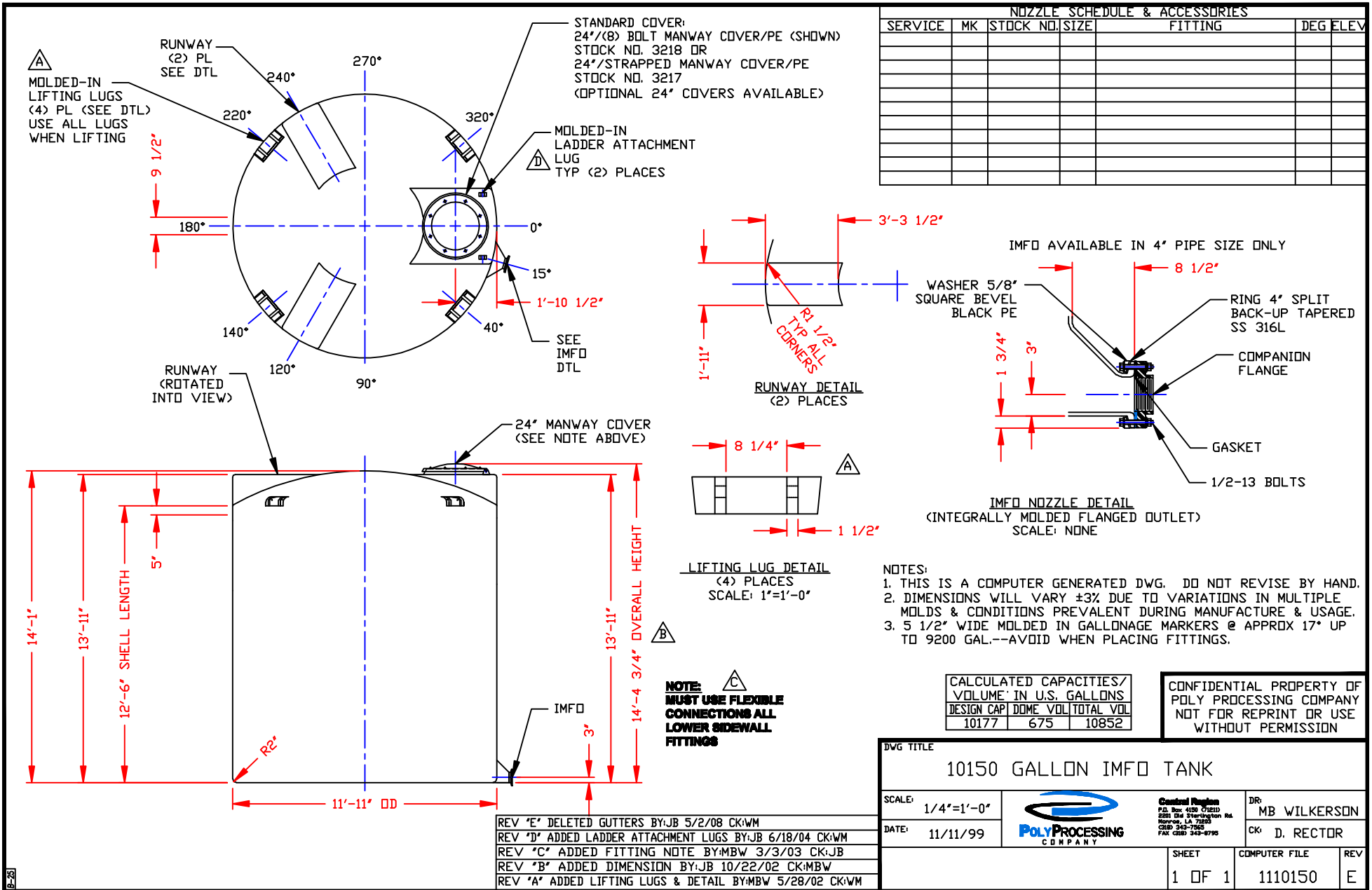

SERVICE	MK	STOCK NO.	SIZE	FITTING	DEG	ELEV

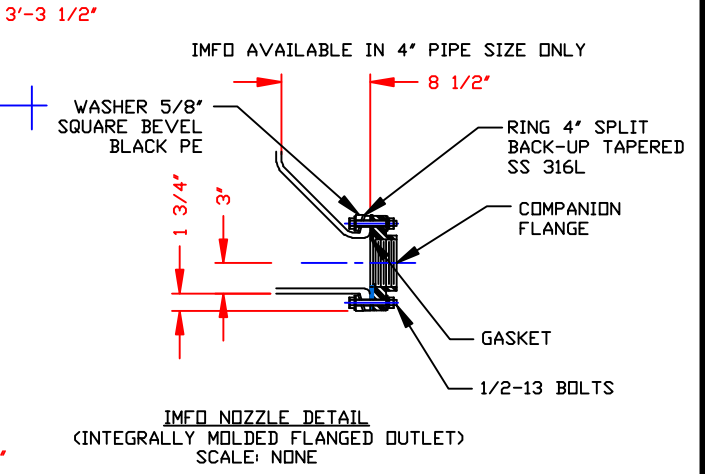

- NOTES:
1. THIS IS A COMPUTER GENERATED DWG. DO NOT REVISE BY HAND.
  2. DIMENSIONS WILL VARY ±3% DUE TO VARIATIONS IN MULTIPLE MOLDS & CONDITIONS PREVALENT DURING MANUFACTURE & USAGE.
  3. 5 1/2" WIDE MOLDED IN GALLONAGE MARKERS @ APPROX 17" UP TO 9200 GAL.--AVOID WHEN PLACING FITTINGS.

CALCULATED CAPACITIES/VOLUME IN U.S. GALLONS		
DESIGN CAP	DOME VOL	TOTAL VOL
10177	675	10852

CONFIDENTIAL PROPERTY OF  
 POLY PROCESSING COMPANY  
 NOT FOR REPRINT OR USE  
 WITHOUT PERMISSION

DWG TITLE		10150 GALLON IMFO TANK	
SCALE:	1/4"=1'-0"		DR:
DATE:	11/11/99		CK:
SHEET		COMPUTER FILE	
1 OF 1		1110150	
		E	

- REV "E" DELETED GUTTERS BY:JB 5/2/08 CK:WM
- REV "D" ADDED LADDER ATTACHMENT LUGS BY:JB 6/18/04 CK:WM
- REV "C" ADDED FITTING NOTE BY:MBW 3/3/03 CK:JB
- REV "B" ADDED DIMENSION BY:JB 10/22/02 CK:MBW
- REV "A" ADDED LIFTING LUGS & DETAIL BY:MBW 5/28/02 CK:WM

**NOTE:**  
 MUST USE FLEXIBLE  
 CONNECTIONS ALL  
 LOWER SIDEWALL  
 FITTINGS