

NON-CONTROLLED COPY  
 INFORMATION SUBJECT TO CHANGE WITHOUT NOTICE  
 VERIFY REV LEVEL OF PAPER COPY WITH REV LEVEL ON PPC WEB SITE

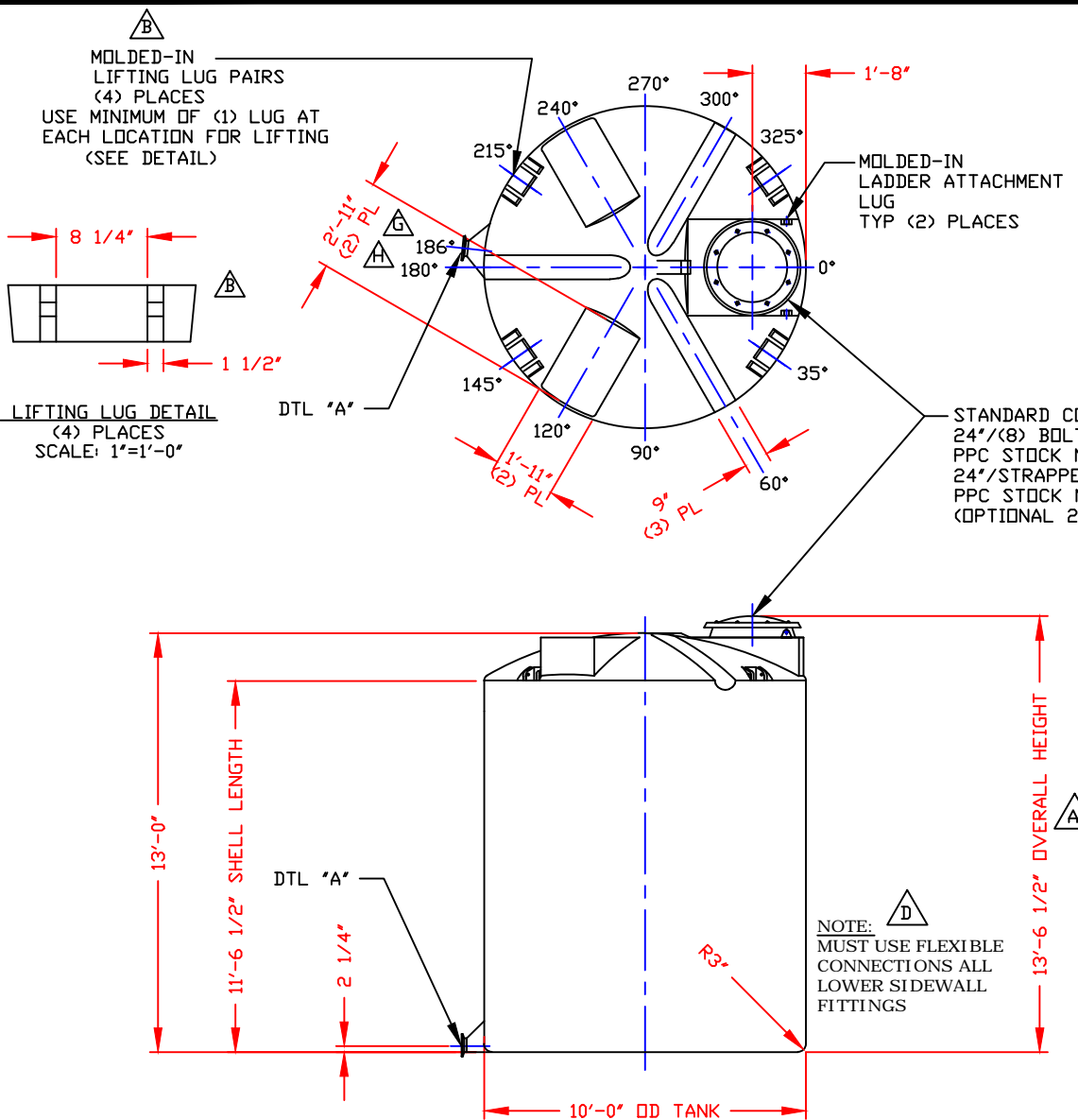

NOZZLE SCHEDULE & ACCESSORIES						
SERVICE	MK	STOCK NO.	SIZE	FITTING	DEG	ELEV

STANDARD COVER:  
 24"/(8) BOLT MANWAY COVER/PE (SHOWN)  
 PPC STOCK NO. 3218 OR  
 24"/STRAPPED MANWAY COVER/PE  
 PPC STOCK NO. 3217  
 (OPTIONAL 24" COVERS AVAILABLE)

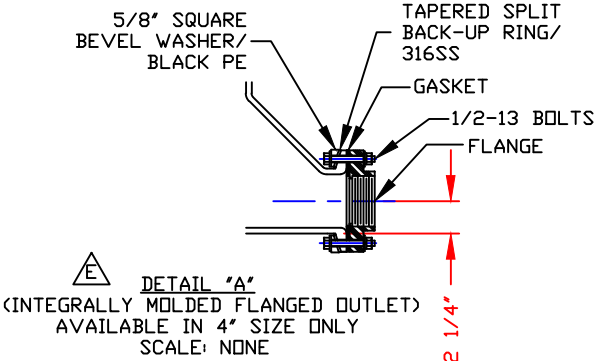

- NOTES**
- THIS IS A COMPUTER GENERATED DWG. DO NOT REVISE BY HAND.
  - DIMENSIONS WILL VARY ±3% DUE TO VARIATIONS IN MULTIPLE MOLDS & CONDITIONS PREVALENT DURING MANUFACTURE & USAGE.
  - NO MOLDED IN GALLONAGE MARKERS THIS TANK.

CALCULATED CAPACITIES/ VOLUME IN U.S. GALLONS		
DESIGN CAP	DOMESTIC VOL	TOTAL VOL
6628	265	6893

CONFIDENTIAL PROPERTY OF  
 POLY PROCESSING COMPANY  
 NOT FOR REPRINT OR USE  
 WITHOUT PERMISSION

DWG TITLE		6600 GALLON IMFO TANK	
SCALE:	1/4"=1'-0"	Western Region P.O. Box 80 8023 South Ash Street Fresno, Calif., CA 95821 (509) 282-4264 FAX (509) 982-6455	DR:
DATE:	3/9/00		CK:
SHEET		COMPUTER FILE	REV
1 OF 1		11106600	H

REV "G" REVISED IMFO LOCATION BY:JB 8/7/09 CK:WM	REV "H" REVISED IMFO LOCATION BY:JB 5/23/16 CK:WM
REV "F" REVISED FOR MOLD MODIFICATION BY:JB 6/16/05 CK:WM	
REV "E" REVISED IMFO STYLE BY:JB 4/30/03 CK:WM	
REV "D" ADDED FITTING NOTE BY:JB 2/27/03 CK:MBW	
REV "C" REVISED STOCK NUMBER BY:JB 2/27/03 CK:MBW	
REV "B" ADDED LIFTING LUGS & DETAIL BY:JB 10/31/02 CK:WM	
REV "A" ADDED DIMENSION BY:JB 10/21/02 CK:MBW	