

NON-CONTROLLED COPY
 INFORMATION SUBJECT TO CHANGE WITHOUT NOTICE
 VERIFY REV LEVEL OF PAPER COPY WITH REV LEVEL ON PPC WEB SITE

NOTES
 1. THIS IS A COMPUTER GENERATED DWG. DO NOT REVISE BY HAND
 2. DIMENSIONS WILL VARY ±3% DUE TO VARIATIONS IN MULTIPLE
 MOLDS & CONDITIONS PREVALENT DURING MANUFACTURE & USAGE.

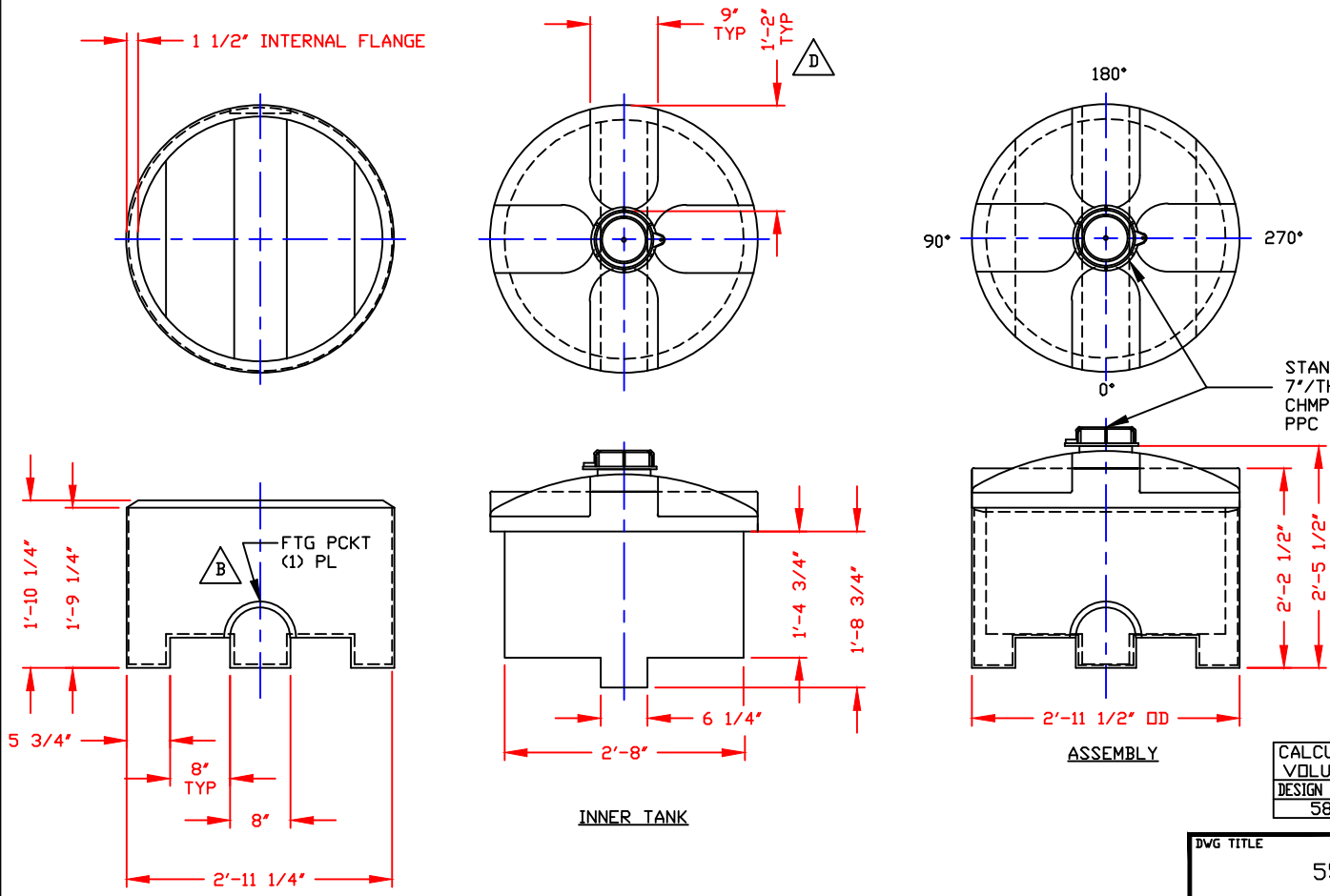

STANDARD COVER: $\triangle C$
 7" TH'D CAP/BLANK/
 CHMPLS/BLACK PE
 PPC STOCK NO. 4565

NOTE: $\triangle A$
 MUST USE FLEXIBLE
 CONNECTIONS ALL
 LOWER SIDEWALL
 FITTINGS

| CALCULATED CAPACITIES/ VOLUME IN U.S. GALLONS | | |
|--|----------|-----------|
| DESIGN CAP | DOME VOL | TOTAL VOL |
| 58 | 11 | 69 |

CONFIDENTIAL PROPERTY OF
 POLY PROCESSING COMPANY
 NOT FOR REPRINT OR USE
 WITHOUT PERMISSION

| | | | |
|-----------|------------|--|---------------|
| DWG TITLE | | 55 GALLON SAFE-TANK ASSEMBLY | |
| SCALE: | 3/4"=1'-0" |  Central Region P.O. Box 4188 CHENIERE 2834 Old Shreveport Rd. Harvey, LA 70059 (504) 343-7825 FAX (504) 343-9795 | DR: |
| DATE: | 11/22/99 | | CK: |
| | | SHEET | COMPUTER FILE |
| | | 1 OF 1 | 2000055 |
| | | | D |

REV "D" REVISED DOME FLATS BY:JB 12/5/12 CK:WM
 REV "C" REVISED COVER BY:JB 7/27/09 CK:WM
 REV "B" ADDED FTG PCKET BY:MBW 7/13/04 CK:JB
 REV "A" ADDED FITTING NOTE BY:MBW 4/15/03 CK:JB