

NON-CONTROLLED COPY
 INFORMATION SUBJECT TO CHANGE WITHOUT NOTICE
 VERIFY REV LEVEL OF PAPER COPY WITH REV LEVEL ON PPC WEB SITE

NOTES
 1. THIS IS A COMPUTER GENERATED DWG. DO NOT REVISE BY HAND.
 2. DIMENSIONS WILL VARY ±3% DUE TO VARIATIONS IN MULTIPLE MOLDS & CONDITIONS PREVELANT DURING MANUFACTURE & USAGE.
 3. OVERALL HEIGHT WILL VARY WITH THE PENETRATION OF THE INNER TANK INTO THE OUTER TANK.

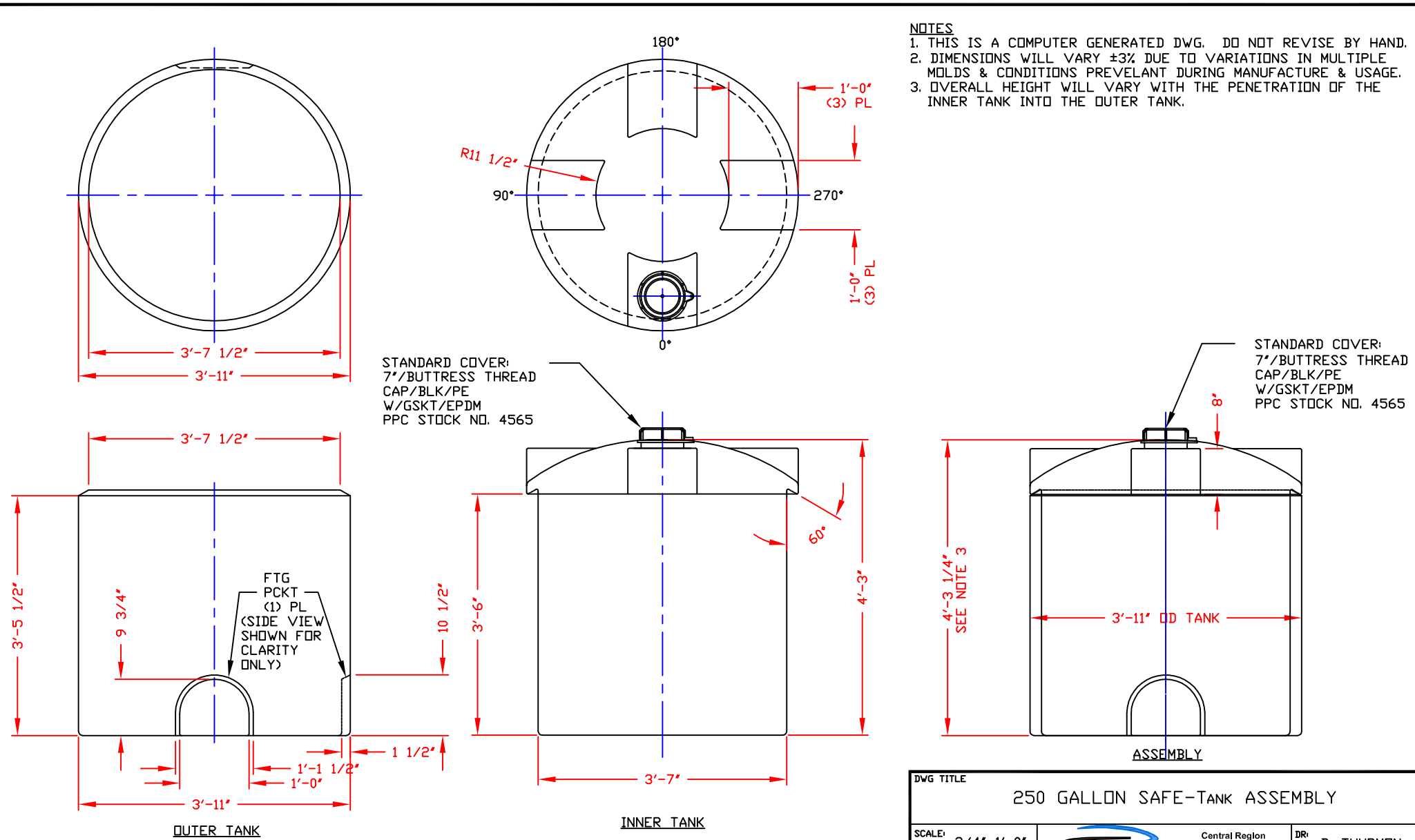

STANDARD COVER:
 7"/BUTTRESS THREAD
 CAP/BLK/PE
 W/GSKT/EPDM
 PPC STOCK NO. 4565

STANDARD COVER:
 7"/BUTTRESS THREAD
 CAP/BLK/PE
 W/GSKT/EPDM
 PPC STOCK NO. 4565

CALCULATED CAPACITIES/ VOLUME IN U.S. GALLONS			
TANK	SHELL	CAP/DOME VOL	TOTAL VOL
INNER	258	25	283
OUTER	304	N/A	304

CONFIDENTIAL PROPERTY OF
 POLY PROCESSING COMPANY
 NOT FOR REPRINT OR USE
 WITHOUT PERMISSION

DWG TITLE			
250 GALLON SAFE-TANK ASSEMBLY			
SCALE:	3/4"=1'-0"	 POLYPROCESSING COMPANY LLC	DR:
DATE:	11/12/12		B. THURMON
		SHEET	COMPUTER FILE
		1 OF 1	2000250
		REV	-