

NON-CONTROLLED COPY  
 INFORMATION SUBJECT TO CHANGE WITHOUT NOTICE  
 VERIFY REV LEVEL OF PAPER COPY WITH REV LEVEL ON PPC WEB SITE

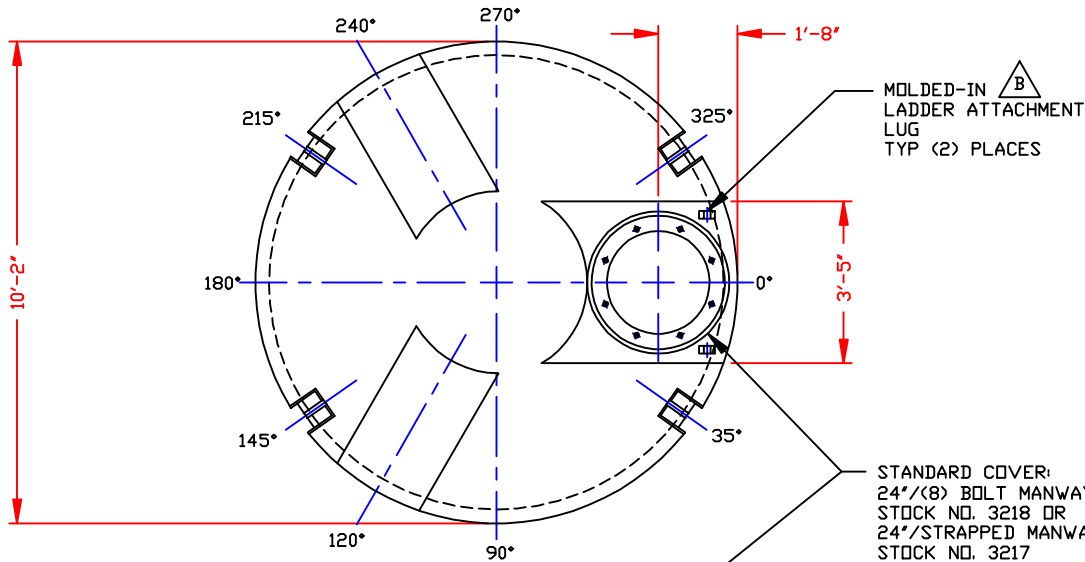

MOLDED-IN LADDER ATTACHMENT LUG TYP (2) PLACES

STANDARD COVER:  
 24" (8) BOLT MANWAY COVER/PE (SHOWN)  
 STOCK NO. 3218 OR  
 24" STRAPPED MANWAY COVER/PE  
 STOCK NO. 3217  
 (OPTIONAL 24" COVERS AVAILABLE)

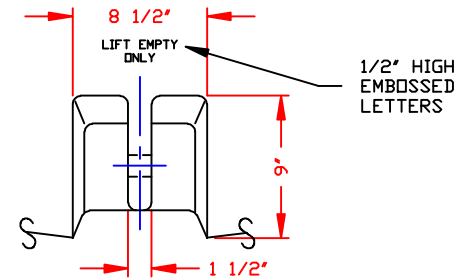

DETAIL "A"  
 SCALE: 1 1/2"=1'-0"

- NOTES:  
 1. THIS IS A COMPUTER GENERATED DWG. DO NOT REVISE BY HAND.  
 2. DIMENSIONS WILL VARY ±3% DUE TO VARIATIONS IN MULTIPLE MOLDS & CONDITIONS PREVALENT DURING MANUFACTURE & USAGE.  
 3. FOR OUTER TANK DTLS SEE COMPUTER FILE NO. 2103550, TITLE "3150 GALLON OUTER SAFE-TANK/3550 GALLON OPEN TOP TANK. FOR ASSEMBLY SEE COMPUTER FILE NO. 2003150A, TITLE "3150 GALLON SAFE-TANK ASSEMBLY".

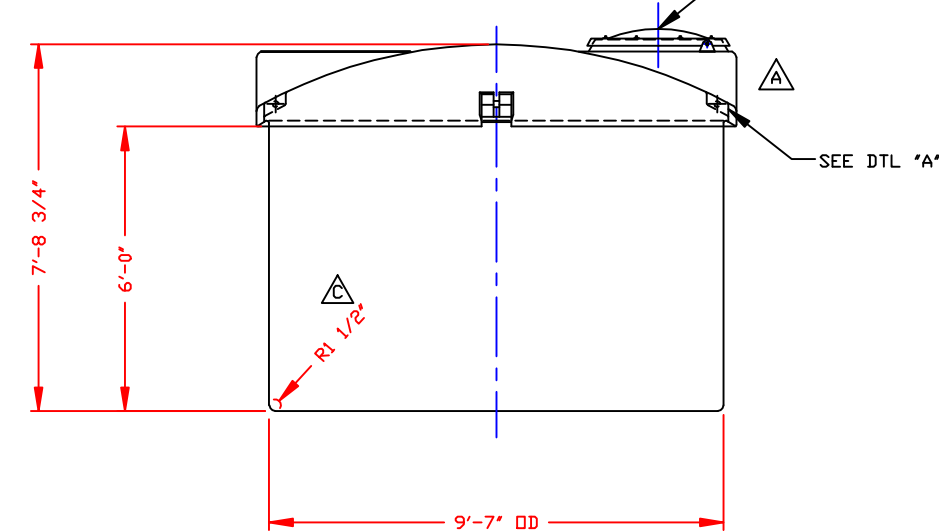

CALCULATED CAPACITIES/ VOLUME IN U.S. GALLONS		
DESIGN CAP	DOME VOL	TOTAL VOL
3191	419	3610

CONFIDENTIAL PROPERTY OF  
 POLY PROCESSING COMPANY  
 NOT FOR REPRINT OR USE  
 WITHOUT PERMISSION

DWG TITLE 3150 GALLON INNER SAFE-TANK				Central Region P.O. Box 450 (71251) 25M Old Worthington Rd. Norcross, LA 72003 (504) 343-7825 FAX (504) 343-9795		IR: MB WILKERSON CK: D. RECTOR		
SCALE:	3/8"=1'-0"	DATE:	12/6/99	SHEET	1 OF 1	COMPUTER FILE	2003150	
							REV	C

- REV "C" REVISED RADIUS BY:JB 3/2/10 CK:WM  
 REV "B" ADDED LADDER ATTACHMENT LUGS BY:JB 10/1/04 CK:WM  
 REV "A" MODIFICATION TO MOLD BY:MBW 9/10/02 CK:JB