

NON-CONTROLLED COPY  
 INFORMATION SUBJECT TO CHANGE WITHOUT NOTICE  
 VERIFY REV LEVEL OF PAPER COPY WITH REV LEVEL ON PPC WEB SITE

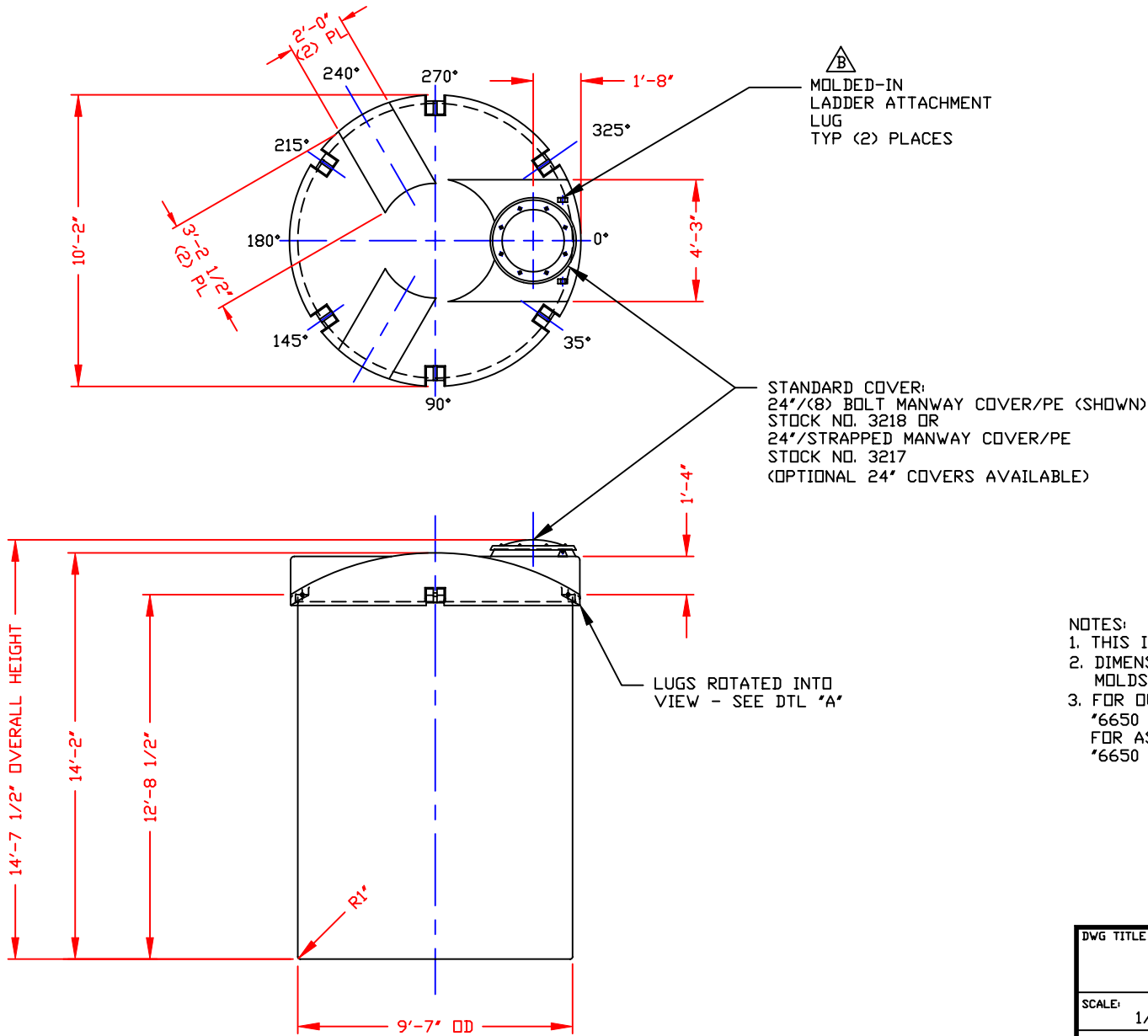

**B**  
 MOLDED-IN  
 LADDER ATTACHMENT  
 LUG  
 TYP (2) PLACES

STANDARD COVER:  
 24"/(8) BOLT MANWAY COVER/PE (SHOWN)  
 STOCK NO. 3218 OR  
 24"/STRAPPED MANWAY COVER/PE  
 STOCK NO. 3217  
 (OPTIONAL 24" COVERS AVAILABLE)

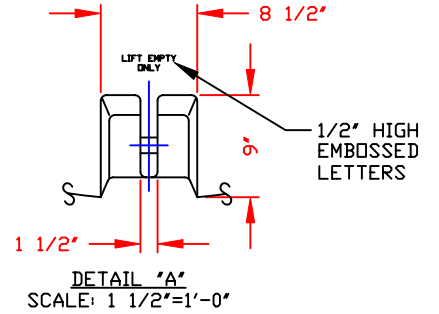

- NOTES:  
 1. THIS IS A COMPUTER GENERATED DWG. DO NOT REVISE BY HAND.  
 2. DIMENSIONS WILL VARY ±3% DUE TO VARIATIONS IN MULTIPLE MOLDS & CONDITIONS PREVALENT DURING MANUFACTURE & USAGE.  
 3. FOR OUTER TANK DTLS SEE COMPUTER FILE NO. 2107450, TITLE "6650 GALLON OUTER SAFE-TANK/7450 GALLON OPEN TOP TANK." FOR ASSEMBLY SEE COMPUTER FILE NO. 2006650A, TITLE "6650 GALLON SAFE-TANK ASSEMBLY."

CALCULATED CAPACITIES/ VOLUME IN U.S. GALLONS		
DESIGN CAP	DOME VOL	TOTAL VOL
6667	419	7086

CONFIDENTIAL PROPERTY OF  
 POLY PROCESSING COMPANY  
 NOT FOR REPRINT OR USE  
 WITHOUT PERMISSION

DWG TITLE 6650 GALLON INNER SAFE-TANK			
SCALE: 1/4"-1'-0"		Central Region P.O. Box 4150 71821D 2510 East Sherington Rd. Marrero, LA 71203 CIBD 343-7543 FAX CIBD 343-8795	DR: MB WILKERSON
DATE: 12/7/99		POLYPROCESSING COMPANY	CK: D. RECTOR
REV *B* ADDED LADDER ATTACHMENT LUGS BY:JB 10/1/04 CK:WM REV *A* MOLD MODIFICATION ADDING LIFTING LUGS & RUNWAYS BY:MBW 12/6/02 CK:JB		SHEET 1 OF 1	COMPUTER FILE 2006650 REV B