

NON-CONTROLLED COPY
 INFORMATION SUBJECT TO CHANGE WITHOUT NOTICE
 VERIFY REV LEVEL OF PAPER COPY WITH REV LEVEL ON PPC WEB SITE

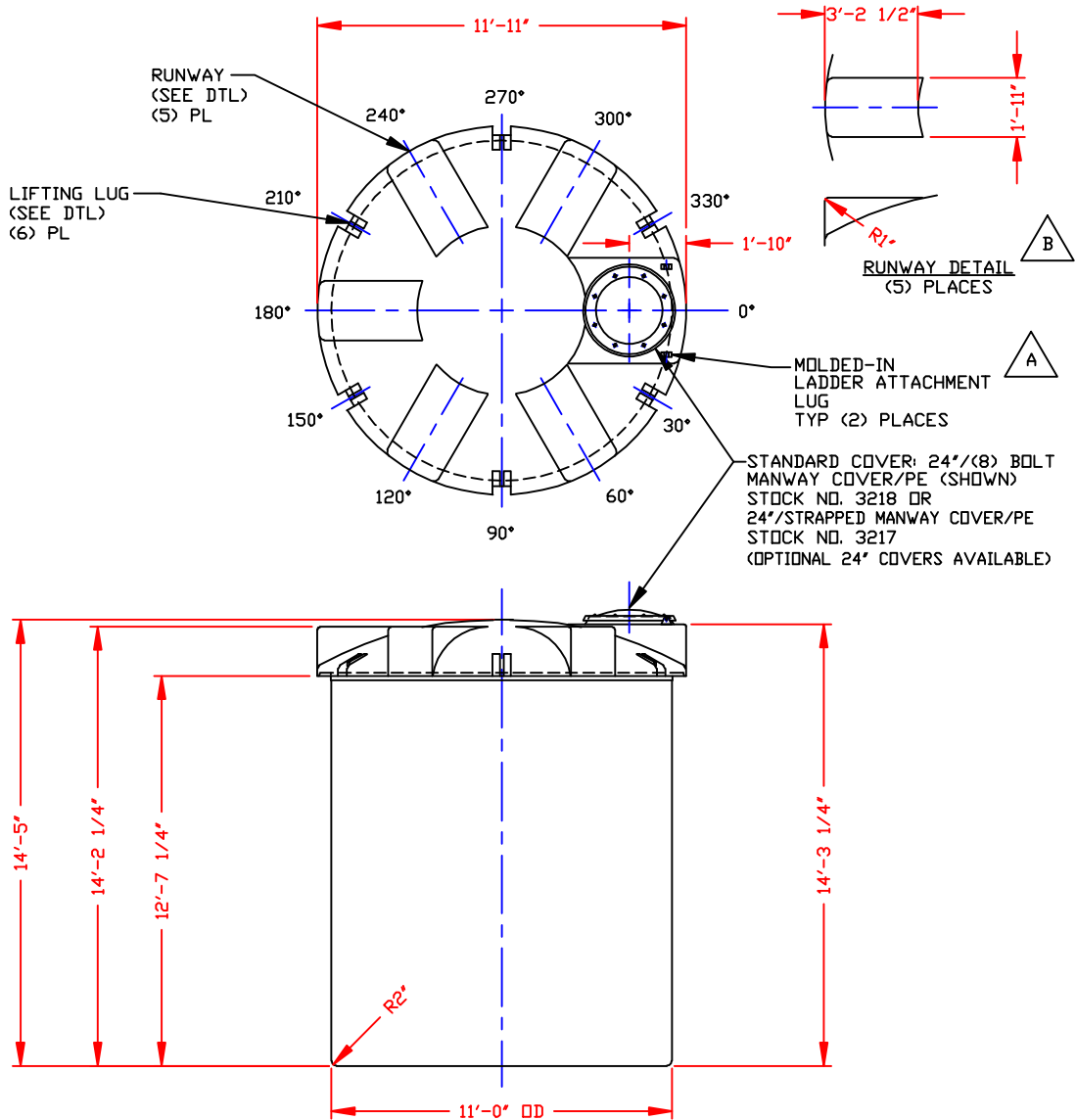

NOZZLE SCHEDULE & ACCESSORIES						
SERVICE	MK	STOCK NO.	SIZE	FITTING	DEG	ELEV

NOTE: MOLDED IN 3/8" HIGH LETTERING ABOVE LIFTING LUGS TO READ:

"LIFT EMPTY ONLY USE ALL LIFTING LUGS"

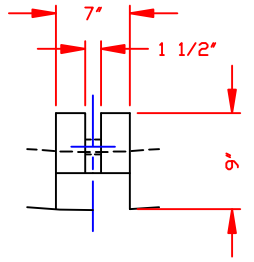

LIFTING LUG DETAIL
 (6) PLACES
 SCALE: 1"=1'-0"

- NOTES
- THIS IS A COMPUTER GENERATED DWG. DO NOT REVISE BY HAND.
 - DIMENSIONS WILL VARY ±3% DUE TO VARIATIONS IN MULTIPLE MOLDS & CONDITIONS PREVALENT DURING MANUFACTURE & USAGE.
 - FOR OUTER TANK DTLS SEE COMPUTER FILE NO. 2110150, TITLE "8700 GALLON OUTER SAFE-TANK/10150 GALLON OPEN TOP TANK." FOR ASSEMBLY DTLS SEE COMPUTER FILE NO. 2008700A, TITLE "8700 GALLON SAFE-TANK ASSEMBLY."

CALCULATED CAPACITIES/ VOLUME IN U.S. GALLONS		
DESIGN CAP	DOME VOL	TOTAL VOL
8727	675	9402

CONFIDENTIAL PROPERTY OF
 PDLY PROCESSING COMPANY
 NOT FOR REPRINT OR USE
 WITHOUT PERMISSION

DWG TITLE: 8700 GALLON INNER SAFE-TANK

SCALE: 1/4"=1'-0"		Central Region P.O. Box 4500 #1250 2501 Old Washington Rd. Norcross, GA 30052 CEN 343-7825 FAX (770) 343-9795	DR: MB WILKERSON
DATE: 12/7/99		CK: D. RECTOR	
SHEET 1 OF 1		COMPUTER FILE 2008700	REV C

REV "C" ADDED RUNWAYS TO ELEV VIEW BY:JB 3/30/10 CK:SN
 REV "B" ADDED (3) RUNWAYS BY:JB 8/18/09 CK:WM
 REV "A" ADDED LADDER ATTACHMENT LUGS BY:JB 9/22/04 CK:WM