

NON-CONTROLLED COPY INFORMATION SUBJECT TO CHANGE WITHOUT NOTICE COPY WILL <u>NOT</u> BE UPDATED	COPY ISSUED BY..... COPY ISSUED ON.....
--	--

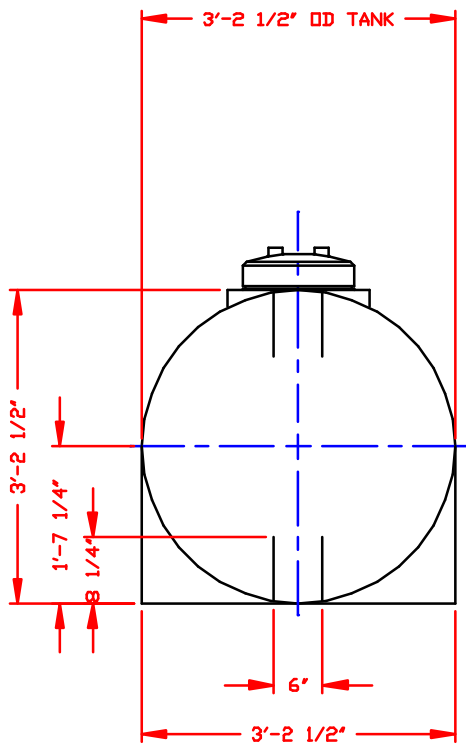

LEFT END

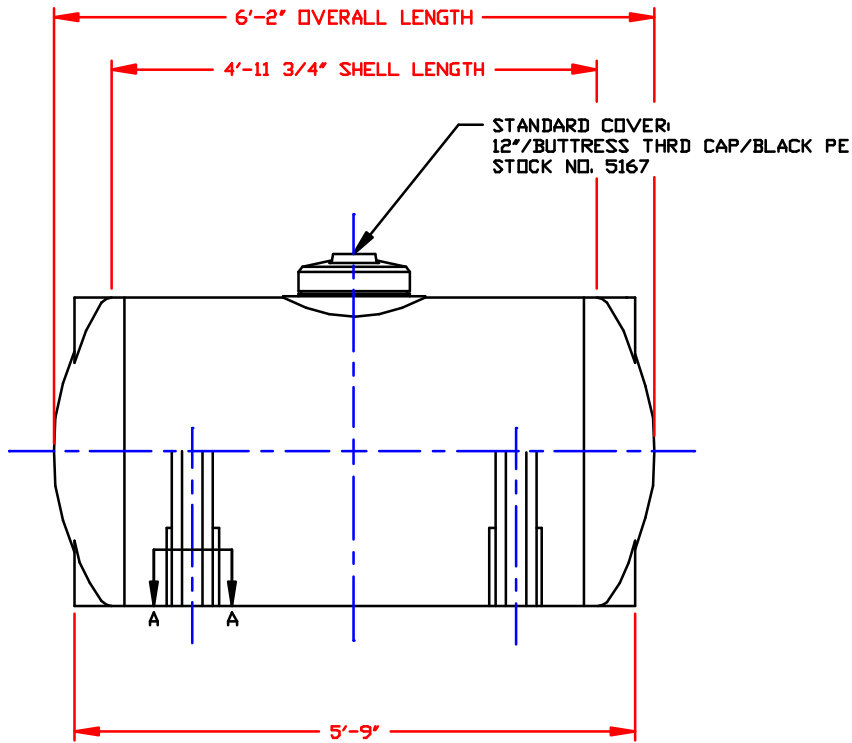

ELEVATION

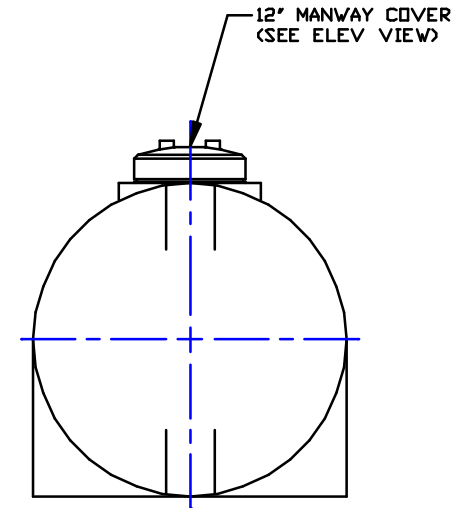

RIGHT END

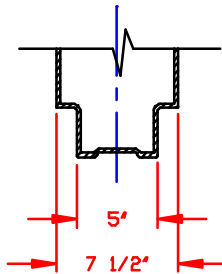

SECTION A-A
SCALE: 1 1/2' = 1'-0"

NOTES

1. THIS IS A COMPUTER GENERATED DWG. DO NOT REVISE BY HAND.
2. DIMENSIONS WILL VARY ±3% DUE TO VARIATIONS IN MULTIPLE MOLDS & CONDITIONS PREVALENT DURING MANUFACTURE & USAGE.
3. MOLDED IN GALLONAGE MARKERS IN BOTH ENDS IN 50 GAL INCREMENTS UP TO 300 GAL. AVOID WHEN PLACING FITTINGS.

CALCULATED CAPACITIES/ VOLUME IN U.S. GALLONS DESIGN CAPACITY 330
--

CONFIDENTIAL PROPERTY OF
 POLY PROCESSING COMPANY
 NOT FOR REPRINT OR USE
 WITHOUT PERMISSION

DWG TITLE 330 GALLON HORIZONTAL LEG TANK			
SCALE: 3/4" = 1'-0" DATE: 2/9/00		General Manager P.O. Box 488, Grand Rapids, MI 49508 269-241-7777 FAX 269-949-0750	DR: MB WILKERSON CK: J. RECTOR
SHEET 1 OF 1		COMPUTER FILE 3400330	REV -