

**NOTES**  
 1. THIS IS A COMPUTER GENERATED DWG. DO NOT REVISE BY HAND.  
 2. MAT'L OF CONSTRUCTION & PAINTING AS SPECIFIED BY PURCHASE ORDER.

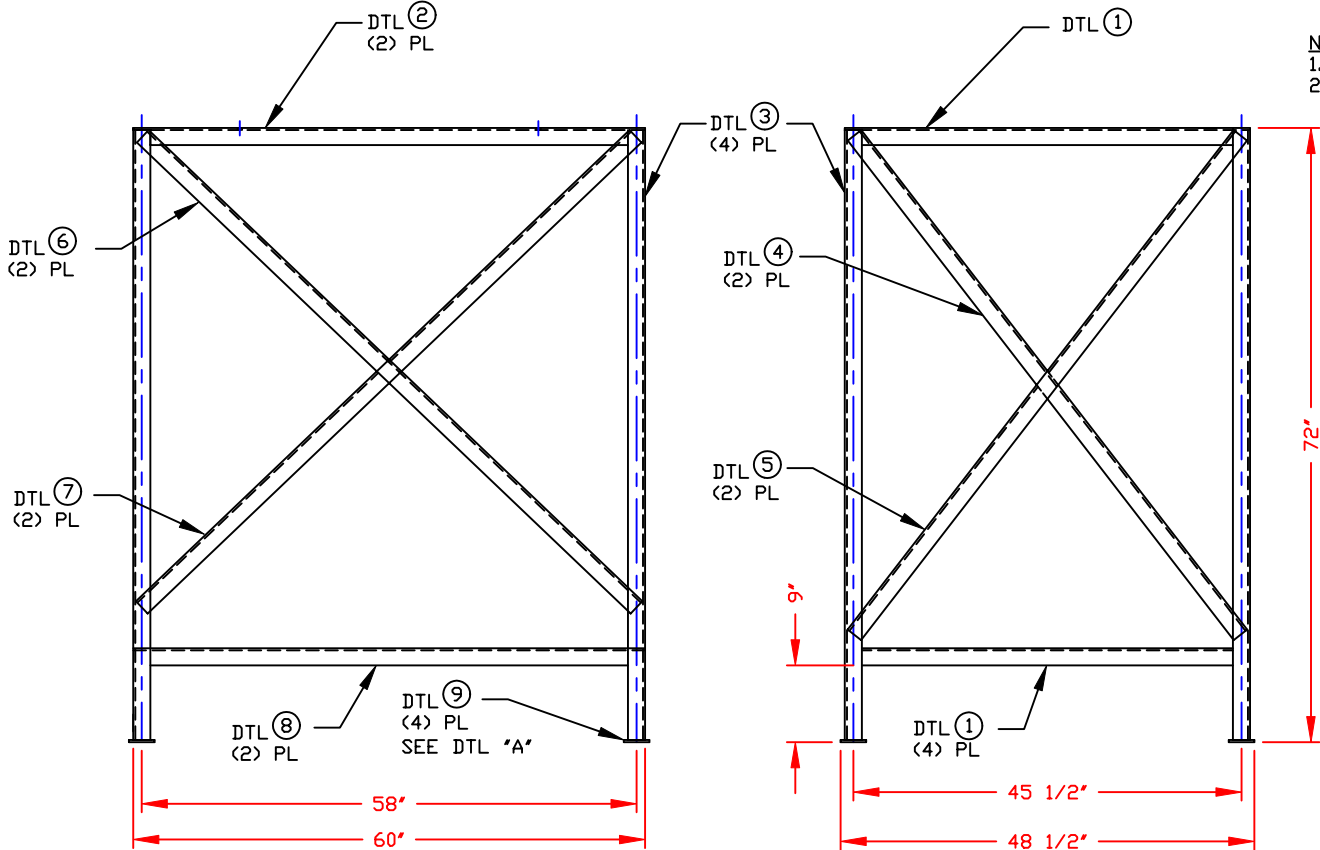

DWG TITLE		6 FT STAND FOR 420 OR 520 GAL HORIZONTAL TANK SKID		
SCALE:	3/4"=12"		DR:	MB WILKERSON
DATE:	10/8/01		CK:	J. BRANTLEY
		SHEET	COMPUTER FILE	REV
		1 OF 2	M3481	-

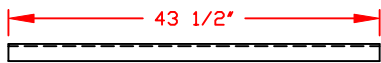

DETAIL ①  
2' X 2' X 1/4' ANGLE  
(4) REQ'D

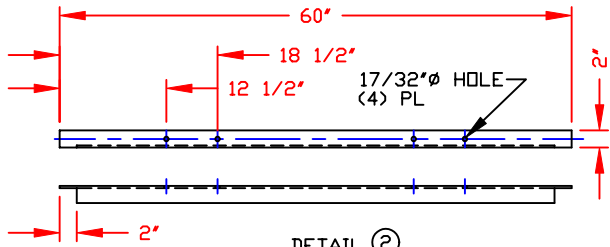

DETAIL ②  
2' X 2' X 1/4' ANGLE  
(2) REQ'D

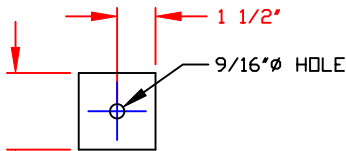

DETAIL ⑨  
1/4" THK PLATE  
(4) REQ'D  
SCALE: 3"=12"

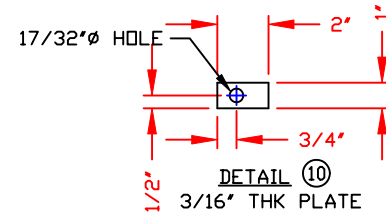

DETAIL ⑩  
3/16" THK PLATE  
(4) REQ'D  
(TO BE SACKED W/DETAIL ⑪)  
SCALE: 3"=12"

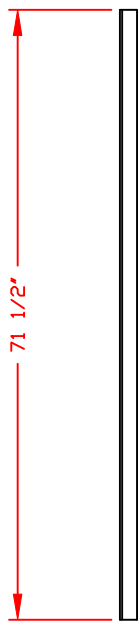

DETAIL ③  
2' X 2' X 1/4' ANGLE  
(4) REQ'D

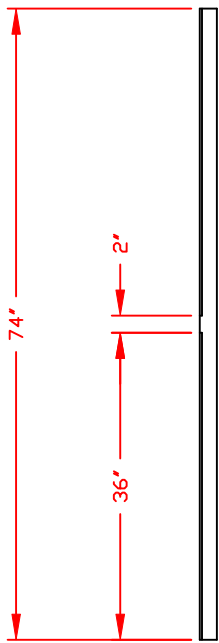

DETAIL ④  
1 1/2' X 1 1/2' X 1/4' ANGLE  
(2) REQ'D

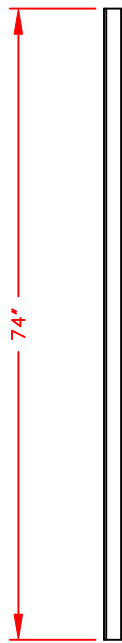

DETAIL ⑤  
1 1/2' X 1 1/2' X 3/16' ANGLE  
(2) REQ'D

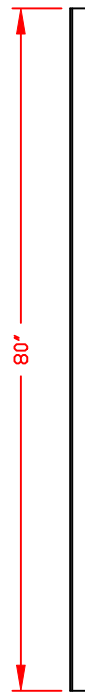

DETAIL ⑥  
1 1/2' X 1 1/2' X 3/16' ANGLE  
(2) REQ'D

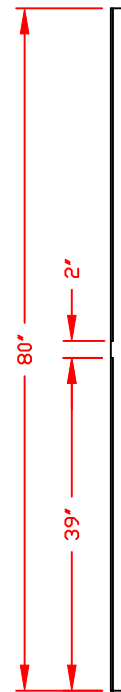

DETAIL ⑦  
1 1/2' X 1 1/2' X 3/16' ANGLE  
(2) REQ'D

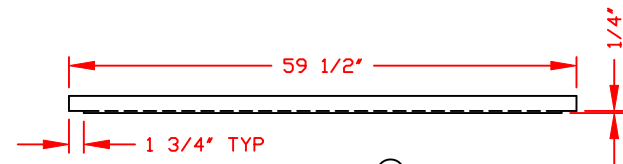

DETAIL ⑧  
2' X 2' X 1/4' ANGLE  
(2) REQ'D

1/2-13 x 2" LG ALL TH'D BOLT - ZINC COATED  
W/(2) FLAT WASHERS  
W/(1) LOCK WASHER  
W/(1) 1/2-13 NUT

DETAIL ⑪  
(4) REQ'D  
(TO BE SACKED W/DETAIL ⑩)

NOTES

1. THIS IS A COMPUTER GENERATED DWG. DO NOT REVISE BY HAND.

DWG TITLE		6 FT STAND FOR 420 OR 520 GAL HORIZONTAL TANK SKID		
SCALE:	3/4"=12'		Central Region P.O. Box 4150 71211 2201 Old Shreveport Rd. Morgan, LA 71253 CND 345-7565 FAX CND 345-9795	DR: MB WILKERSON
DATE:	10/8/01		CK: J. BRANTLEY	
		SHEET	COMPUTER FILE	REV
		2 OF 2	M3481	-